



## WORKTABLE WITH INTEGRAL SINK SSWT-SERIES— OPEN BASE STAINLESS STEEL WORKTABLE W/ INTEGRAL SINK

PROJECT#: \_\_\_\_\_

ITEM# \_\_\_\_\_

MODEL# \_\_\_\_\_

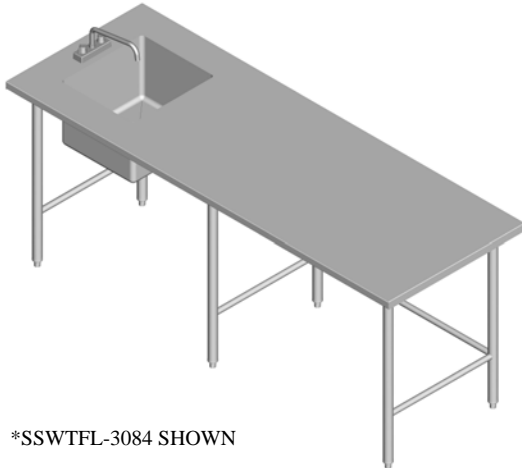

\*SSWTF1L-3084 SHOWN

### SPECIFICATIONS:

**STANDARD— SSWT-Series: 300 Series Stainless Top & 300 Series Stainless Undershef**

**TOP:** 16 GA.  
300 Series Stainless

**SINK BOWL:** 16 GA.  
300 Series Stainless

**CROSS BRACING:** 1" Diameter  
Tubular Stainless Steel

**LEGS:** 1 5/8" Diameter  
Tubular Stainless Steel

**REINFORCING:** Formed Channel Fastened to  
Top. Legs Welded to Channel

### CONSTRUCTION:

- ◆ All Table Connection Points Fully Welded for Maximum Rigidity and Long Life
- ◆ Sink Bowl Integrally Welded to Top
- ◆ 12" Deep Sink Bowl Supplied with Die Stamped Drain Opening to fit a 3 1/2" Drain with 1 1/2" IPS Connection
- ◆ Flat Top Models Designed For Deck Mounted Faucet KN41-4006-TE1 (supplied standard)
- ◆ Backsplash Models Designed For Splash Mounted Faucet KN45-4006 (supplied standard)
- ◆ S/S Adjustable Bullet Feet
- ◆ Sound Deadening Between Top and Reinforcing Channel
- ◆ S/S Cross Bracing Welded to Legs
- ◆ Table is Polished to #3 Finish\_ Working Height 35" to 36 1/4"
- ◆ Tables Above 78" Will Require (3) Sets of Legs

STANDARD - SSWTF SERIES W/ FLAT TOP						
MODEL NUMBER (SINK ON LEFT)	QTY	MODEL NUMBER (SINK ON RIGHT)	QTY	WIDTH (INCHES)	LENGTH (INCHES)	SHIPPING WEIGHT (LBS)
SSWTF1L-3048		SSWTF1R-3048		30	48	85
SSWTF1L-3054		SSWTF1R-3054		30	54	96
SSWTF1L-3060		SSWTF1R-3060		30	60	104
SSWTF1L-3066		SSWTF1R-3066		30	66	113
SSWTF1L-3072		SSWTF1R-3072		30	72	121
SSWTF1L-3078		SSWTF1R-3078		30	78	134
SSWTF1L-3084		SSWTF1R-3084		30	84	146
SSWTF1L-3090		SSWTF1R-3090		30	90	150
SSWTF1L-3096		SSWTF1R-3096		30	96	153
SSWTF1L-30102		SSWTF1R-30102		30	102	161
SSWTF1L-30108		SSWTF1R-30108		30	108	169
SSWTF1L-30114		SSWTF1R-30114		30	114	176
SSWTF1L-30120		SSWTF1R-30120		30	120	184

STANDARD - SSWTF1 SERIES W/ BACKSPLASH						
MODEL NUMBER (SINK ON LEFT)	QTY	MODEL NUMBER (SINK ON RIGHT)	QTY	WIDTH (INCHES)	LENGTH (INCHES)	SHIPPING WEIGHT (LBS)
SSWTF1L-3048		SSWTF1R-3048		30	48	86
SSWTF1L-3054		SSWTF1R-3054		30	54	97
SSWTF1L-3060		SSWTF1R-3060		30	60	105
SSWTF1L-3066		SSWTF1R-3066		30	66	114
SSWTF1L-3072		SSWTF1R-3072		30	72	122
SSWTF1L-3078		SSWTF1R-3078		30	78	135
SSWTF1L-3084		SSWTF1R-3084		30	84	147
SSWTF1L-3090		SSWTF1R-3090		30	90	151
SSWTF1L-3096		SSWTF1R-3096		30	96	154
SSWTF1L-30102		SSWTF1R-30102		30	102	162
SSWTF1L-30108		SSWTF1R-30108		30	108	170
SSWTF1L-30114		SSWTF1R-30114		30	114	177
SSWTF1L-30120		SSWTF1R-30120		30	120	185

