

Ultimate Cleaning by

AQUA·SCRUBBER

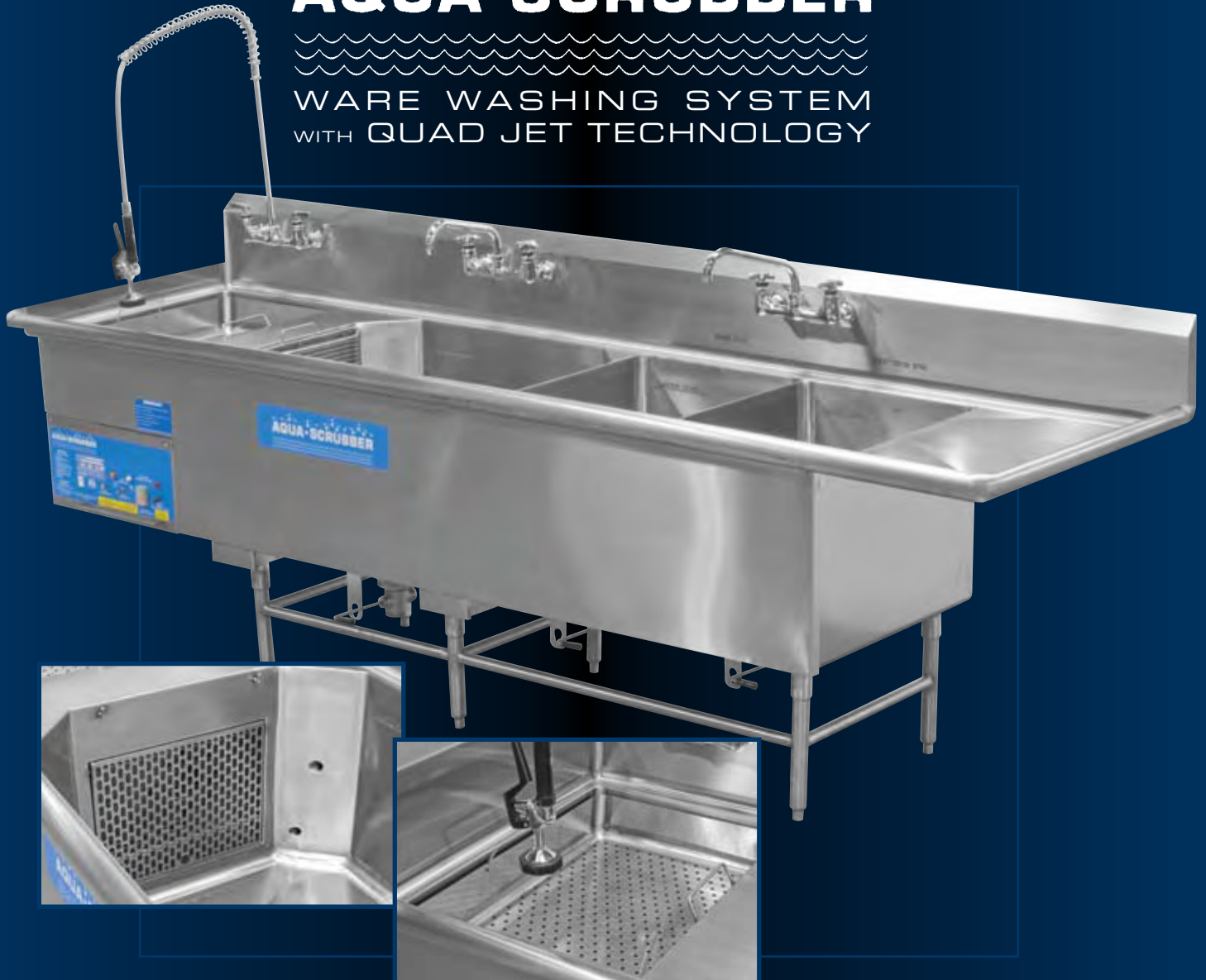

WARE WASHING SYSTEM
WITH QUAD JET TECHNOLOGY



amtekco



A Wasserstrom Company

Manufacturers of Quality Products for the Food Marketing Industry

1205 Refugee Road • Columbus, Ohio 43207
800-336-4677 or 614-228-6590 • Fax: 614-737-8017
www.amtekco.com

Standard features that make your Aqua•Scrubber™ THE value for your ware washing needs:

- 14 gauge stainless steel type 304
- 2 HP wash pump motor TEFC
- Easy clean seamless front panel
- Welded support legs with stainless steel bullet feet
- Fast Flow mixing faucet (2 furnished w/rinse bowls over 20")
- Utensil basket (stainless steel wire)
- Heater with low water protection and dual temperature control
- Control panel enclosure (NEMA 4X)
- Standard models to choose from

Choose the size and features you need:

- Basket-style high-capacity lever action waste drain
- Undershelf on clean end drain board
- Sink overflows
- Pump timer – 1-8 hours
- Overshelf with mounting bracket (12" increments, 36" and up)
- Disposal and cone (in soiled drain board, 48" minimum length)
- Scrap trough for disposal
- Shelves, cantilever or wall mounted
- End splash
- Scrapper drain board with pre-rinse faucet

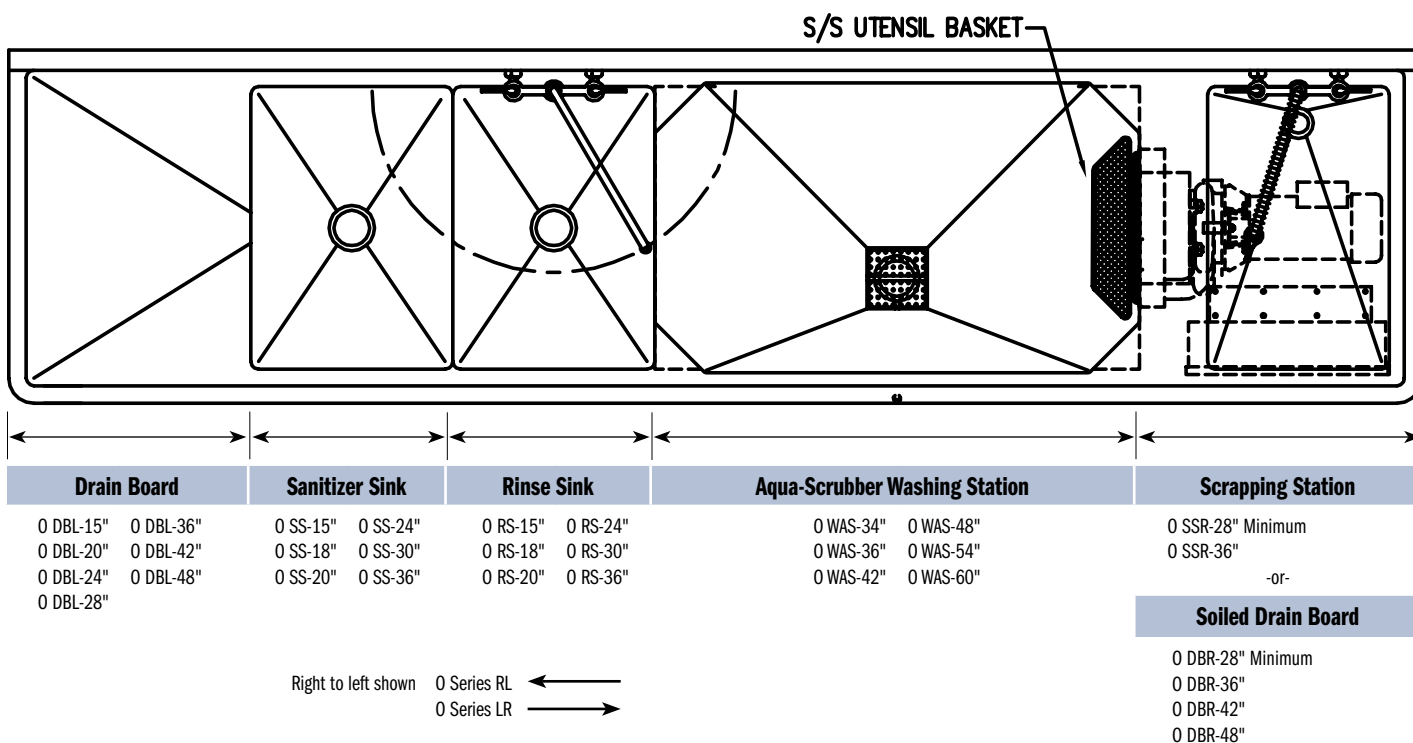

Specifications:

Construction

Entire unit constructed of type 304 polished stainless steel. Sinks and drain boards are constructed of 14 gauge. All interior corners to be covered to 3/4" radius with spherical intersections. Top shall be of 14 gauge stainless steel all welded construction with 11" high back splash and 3" high splash on front and sides with 1-3/4" rolled edge. The wash sink is designed with an exclusive patent pending Quad Jet design consisting of two jets per corner mounted at different levels and angles for optimum scrubbing action. The unique slanted corners are designed to prevent nesting of pots and pans. Intake manifold to include an access panel for easy cleaning of intake chamber, heater and probes. The pump is heavy-duty brass construction. The pump capacity varies with the Aqua-Scrubber size. The motor is 2 HP totally enclosed, fan cooled with permanently sealed bearings. The wash sink is firmly supported by heavy-gauge stainless steel channels welded to underside of sink. H-frame leg assemblies are removable and provided with stainless steel adjustable bullet feet.

Control Panel

Control enclosures to be of stainless steel type 304 completely welded and waterproof (NEMA 4X). On/Off power switch, dual water temperature switch (low and high), on/off pump motor switch and reset switch.

Electrical Specifications

Heater	2.5 KW Immersion Rated 208/240V/60/IPH	Rated Amp 12.0	Dedicated Circuit
Pump	2HP (TEFC) Motor Rated 208/230V/60/IPH	9.2	
Cord & Plug	NEMA L6-30P Plug	Total Load 21.2 Amp	30 Amp

Aqua-Scrubber is built tough.

However, if service is required, your new system is backed by:

- 1 year parts and labor warranty
- Heavy-duty parts that are designed to fit your system
- Nationwide service network. Call 1-800-344-4802 for 24 hr./7 day week



Patent Des. 415,323

