

Refrigerated Produce Case

Engineered for store ambient conditions not to exceed
75 degrees and 50% relative humidity.



amtekco

❖ A Wasserstrom Company

Manufacturers of Quality Products for the Food Marketing Industry

1205 Refugee Road • Columbus, Ohio 43207
800-336-4677 or 614-228-6590 • Fax: 614-737-8017
www.amtekco.com

Refrigerated Produce Case

MODEL NUMBER	CASE LENGTH	REFRIGERATION CAPACITY (BTUH)		ELECTRICAL			
		PARALLEL	CONVENTIONAL	REMOTE		SELF-CONTAINED	
				VOLTAGE	AMPS	AMPS	PLUG
ARPC-4	4'	4,400	4,576	120V	2A	20.3A	NEMA L5-30P
ARPC-6	6'	6,600	6,864	120V	2A	24A	NEMA L5-30P
ARPC-8	8'	8,800	9,152	120V/208V	2A	17.3A	NEMA L14-30R

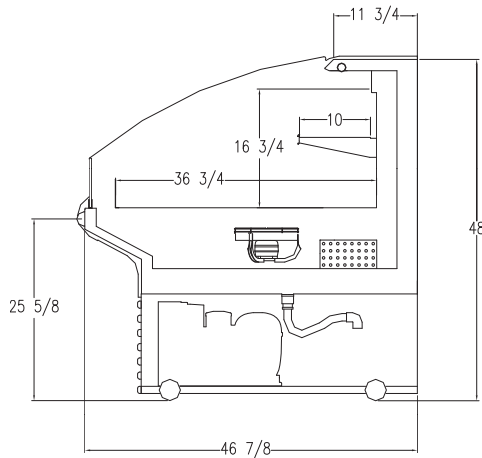

Standard features:

- Open base
- Durable powder coated finish interior & exterior
- Polished bright stainless steel interior ends
- Electronic programmable ECM fan motors
- Etched load line at ends
- Stainless steel trim guard for cart protection
- 2" half round continuous bumper
- Solar digital thermometer
- Adjustable 10" deep mezzanine shelf
- Heavy-duty swivel caster, 2 locking (self-contained only)
- Engineered to hold products at 35 – 41 degrees
- Conforms to UL 471, NSF-7 and CAN/CSA C22.2

Self-contained option:

- Copeland condensing unit
- 110V condensation evaporator pan
- Cool air intake through front

Self-contained option (continued):

- Warm air discharge at back to prevent re-circulation issues
- Exhaust air duct is standard to allow cases to be placed back-to-back
- Sporlan internal equalized expansion valve
- Dixel electronic controller features automatic defrost
- NEMA plug and cord provided

Remote option:

- Sporlan internal equalized expansion valve per refr. type
- Optional set up for third-party control probes, specified by customer
- Optional Glycol refrigeration set up

Other options available:

- Stainless steel construction, interior & exterior
- LED lights
- Display risers to minimize capacity while providing full display
- 10-degree down slant angled shelf
- Shelf depth as required by customer (only on down slant config.)
- Custom powder coated finish, color specified by customer
- Natural wood exterior cladding
- Liquid line ball valve

Contact your Amtekco sales representative: 1-800-336-4677

amtekco

A Wasserstrom Company

Manufacturers of Quality Products for the Food Marketing Industry

Equipment That Means Business